

SHORT ANSWER. Write the word or phrase that best completes each statement or answers the question.

Graph the piecewise defined function.

1)

$$f(x) = \begin{cases} x - 5 & \text{if } x < 1 \\ 1 & \text{if } x \geq 1 \end{cases}$$

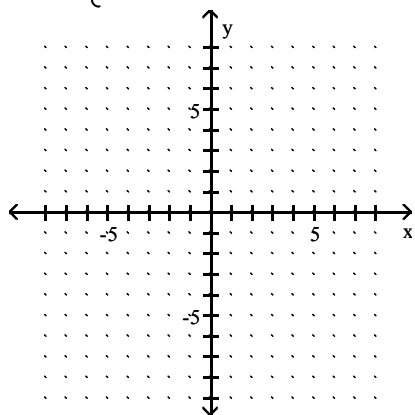

1) _____

2)

$$f(x) = \begin{cases} 2 & \text{if } x \leq -1 \\ -1 + x & \text{if } x > -1 \end{cases}$$

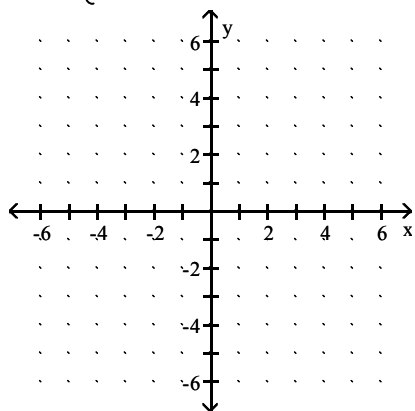

2) _____

3)

$$f(x) = \begin{cases} 4x + 2 & \text{if } x \leq 0 \\ \frac{1}{2}x - 4 & \text{if } x > 0 \end{cases}$$

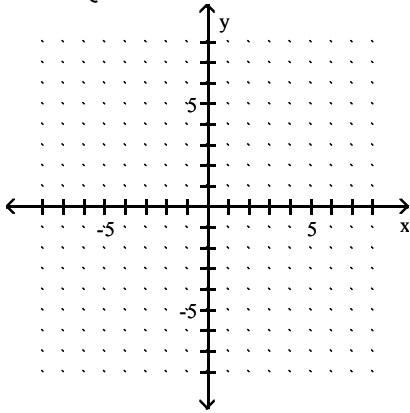

3) _____

4)

$$f(x) = \begin{cases} -2x + 5 & \text{if } x < 0 \\ 5x - 1 & \text{if } x \geq 0 \end{cases}$$

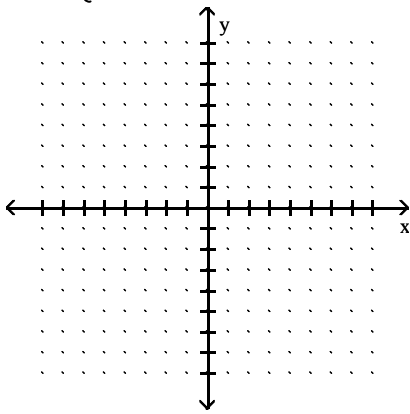

4) _____

5)

$$f(x) = \begin{cases} 1 & \text{if } x < -1 \\ -5 & \text{if } x \geq -1 \end{cases}$$

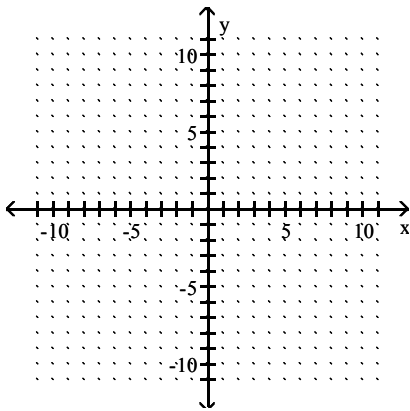

5) _____

Graph the function.

6) $f(x) = |x| + 4$

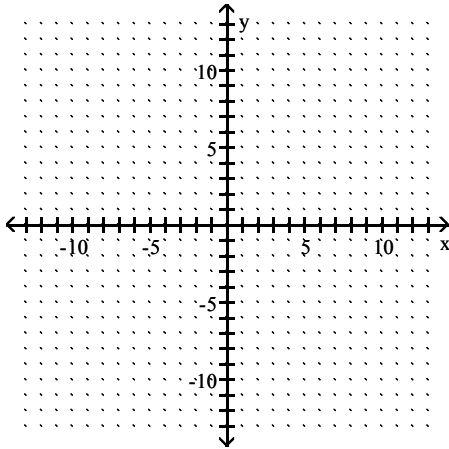

6) _____

7) $f(x) = x^2 + 3$

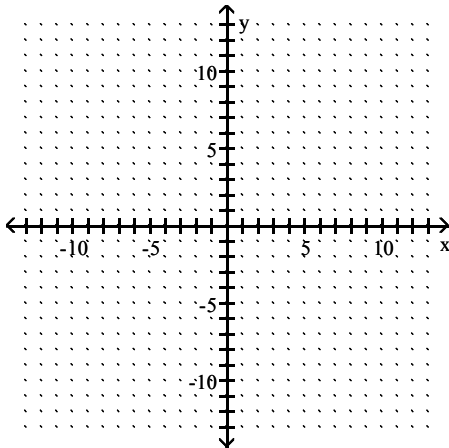

7) _____

8) $f(x) = \sqrt{x} + 3$

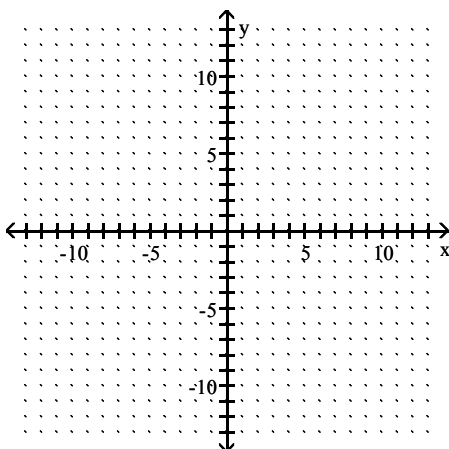

8) _____

9) $f(x) = |x - 3|$

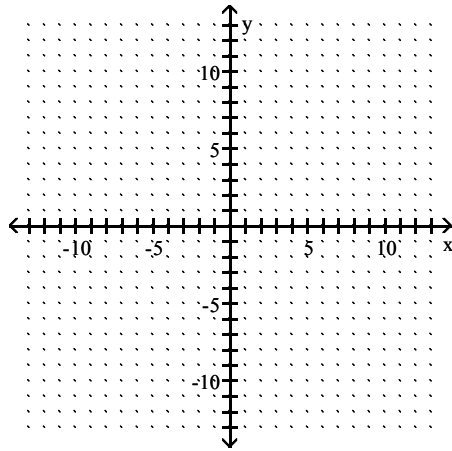

9) _____

10) $f(x) = (x + 4)^2$

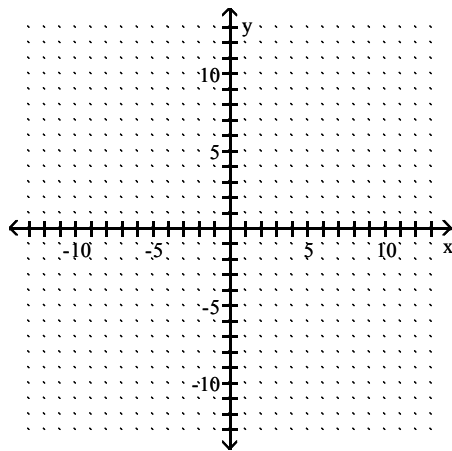

10) _____

11) $f(x) = \sqrt{x - 5}$

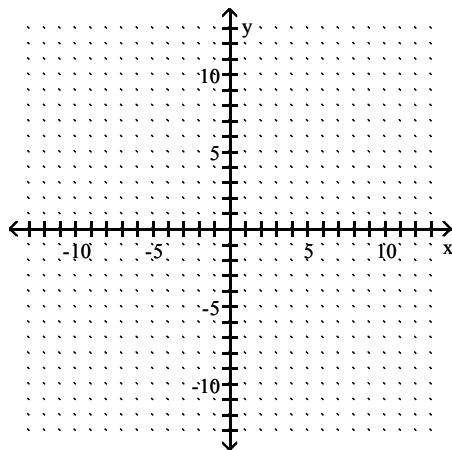

11) _____

12) $f(x) = |x + 6| + 4$

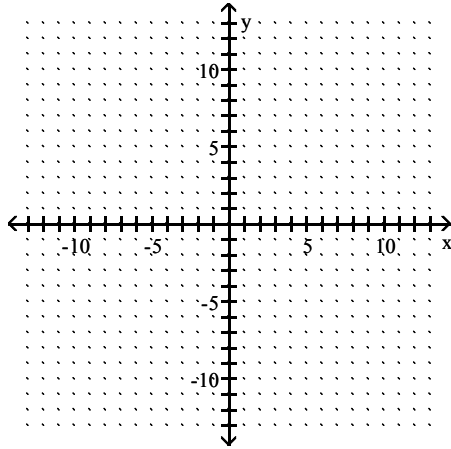

12) _____

13) $f(x) = (x - 2)^2 + 6$

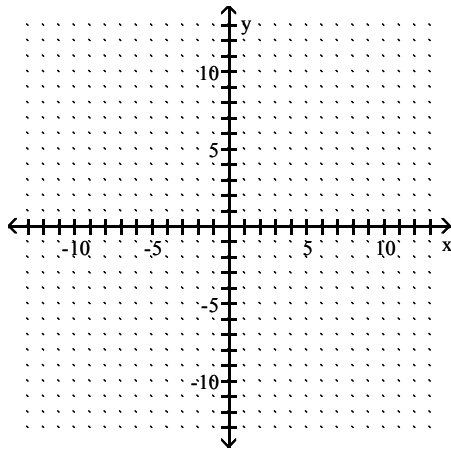

13) _____

14) $f(x) = \sqrt{x - 3} + 7$

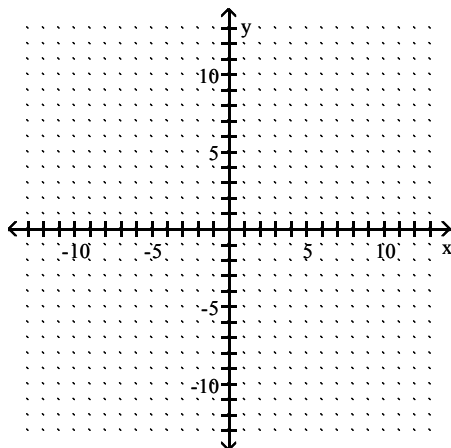

14) _____

15) $f(x) = -|x|$

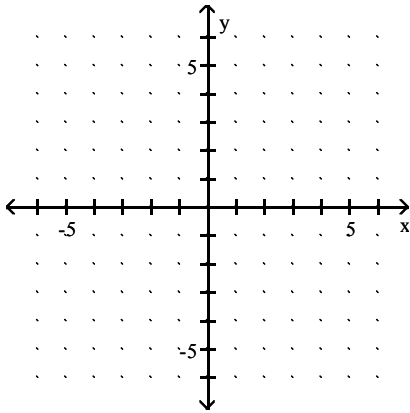

15) _____

16) $f(x) = -x^2$

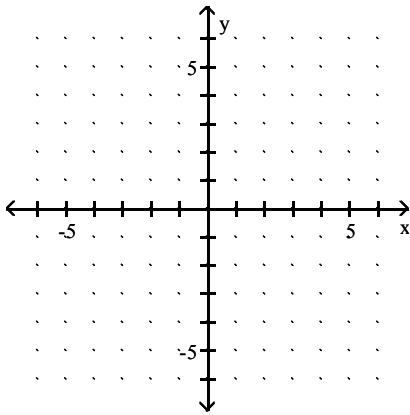

16) _____

17) $f(x) = -|x - 3|$

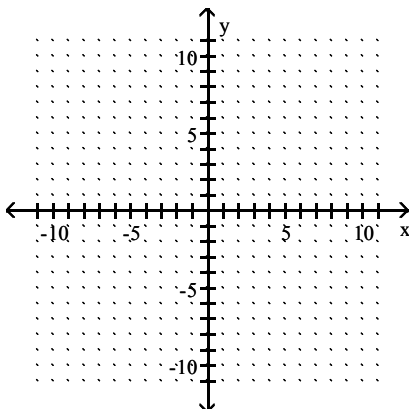

17) _____

18) $f(x) = -(x + 1)^2$

18) _____

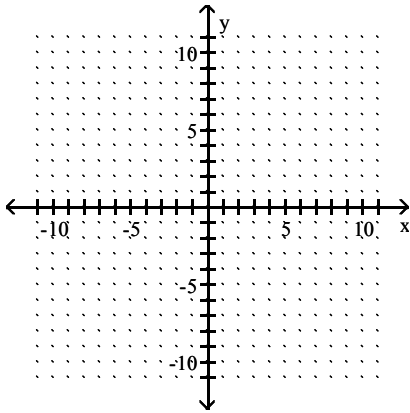

19) $f(x) = -\sqrt{x + 4}$

19) _____

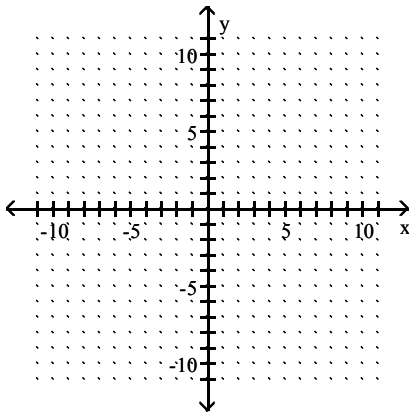

20) $f(x) = -\sqrt{x - 4} - 3$

20) _____

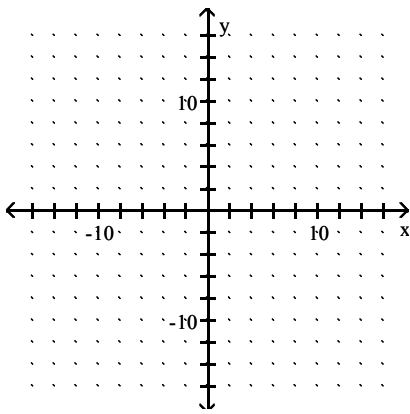

21) $f(x) = -(x + 7)^2 - 5$

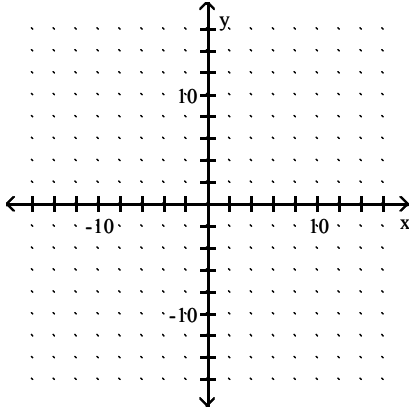

21) _____

22) $f(x) = -|x - 6| + 3$

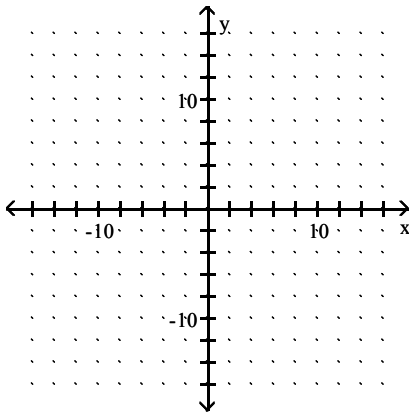

22) _____

Answer Key

Testname: PRACTICE FOR THE EXAM (3.6)

1)

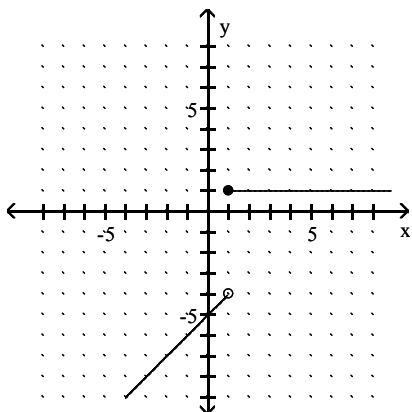

2)

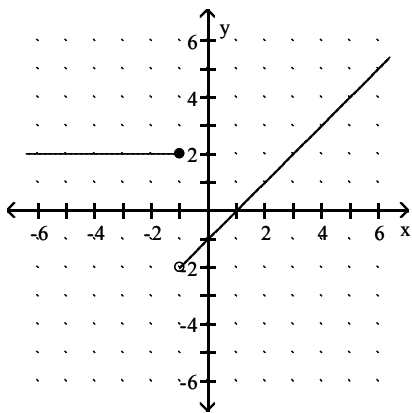

3)

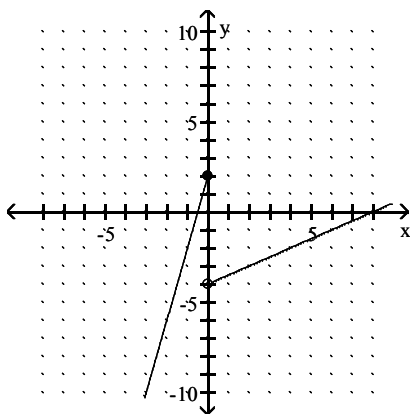

Answer Key

Testname: PRACTICE FOR THE EXAM (3.6)

4)

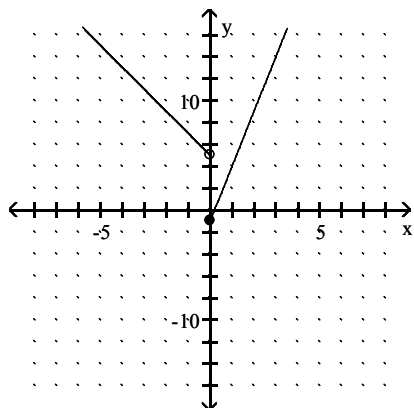

5)

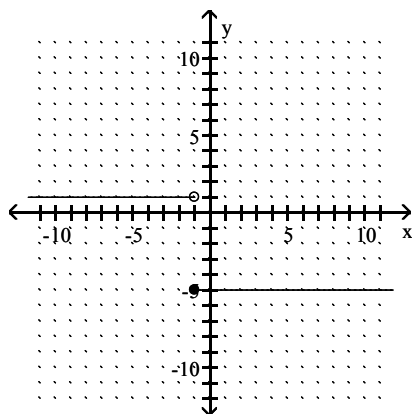

6)

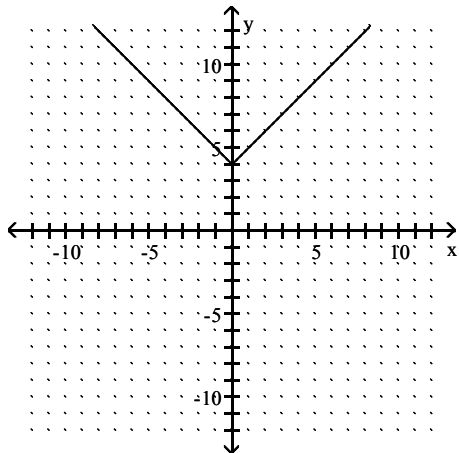

Answer Key

Testname: PRACTICE FOR THE EXAM (3.6)

7)

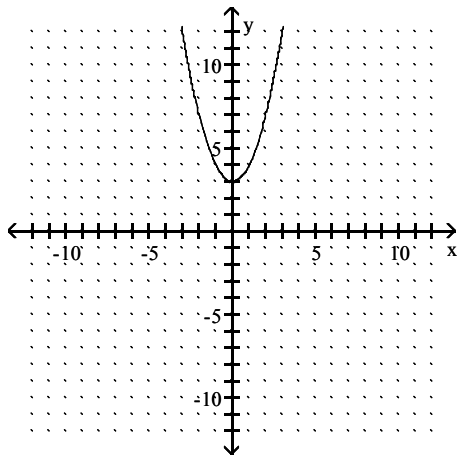

8)

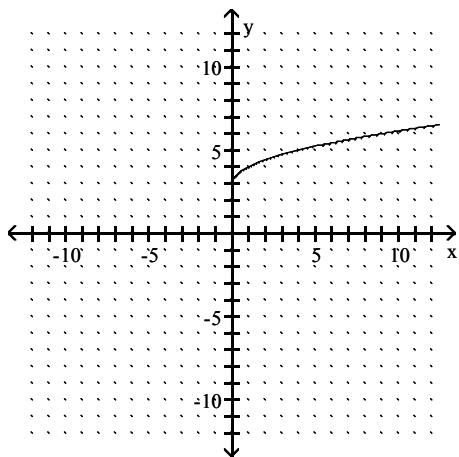

9)

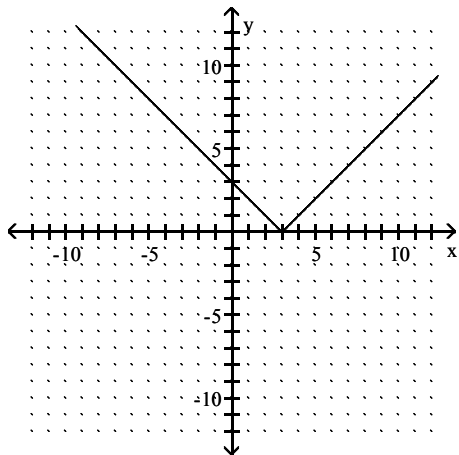

Answer Key

Testname: PRACTICE FOR THE EXAM (3.6)

10)

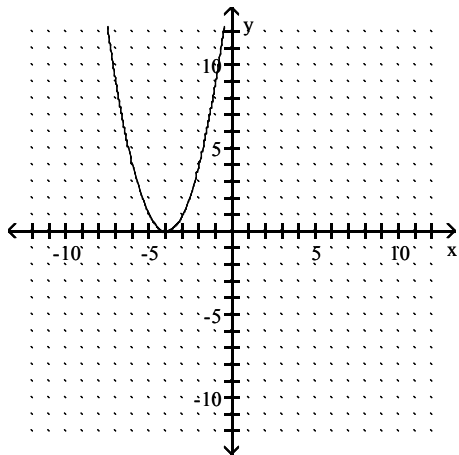

11)

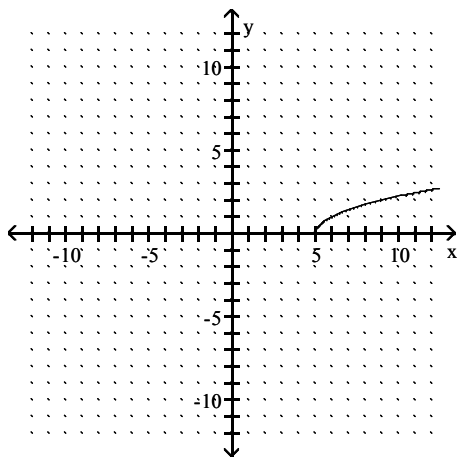

12)

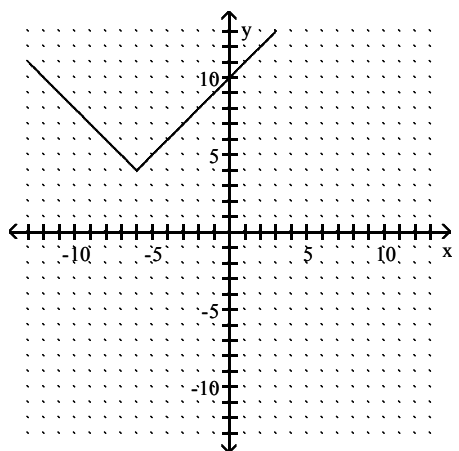

Answer Key

Testname: PRACTICE FOR THE EXAM (3.6)

13)

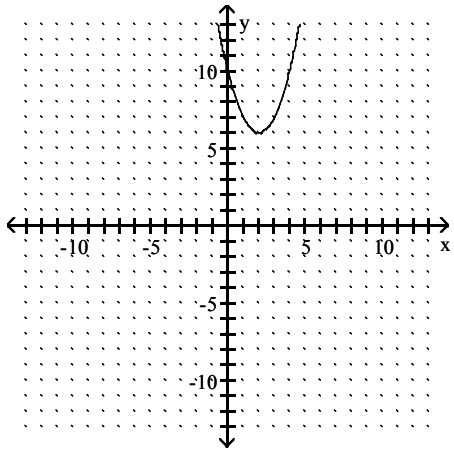

14)

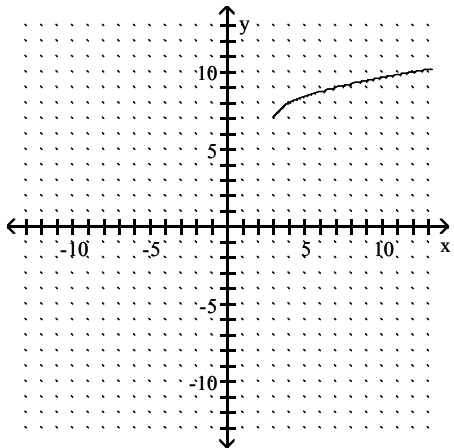

15)

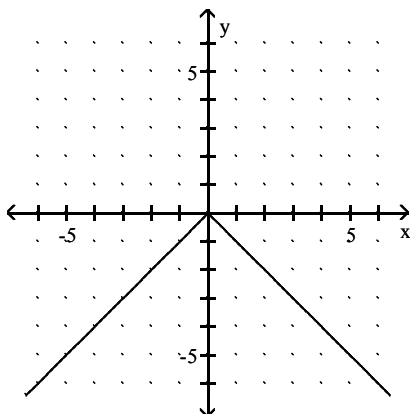

Answer Key

Testname: PRACTICE FOR THE EXAM (3.6)

16)

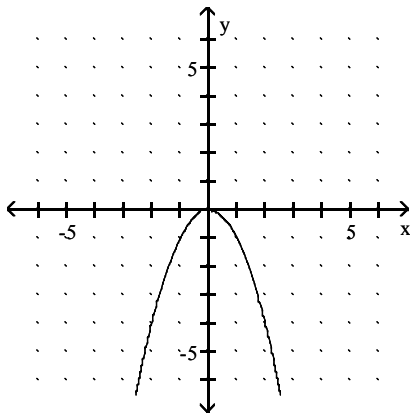

17)

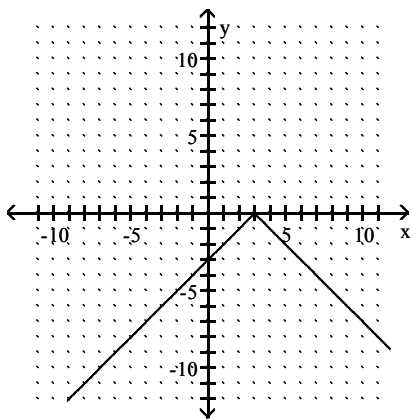

18)

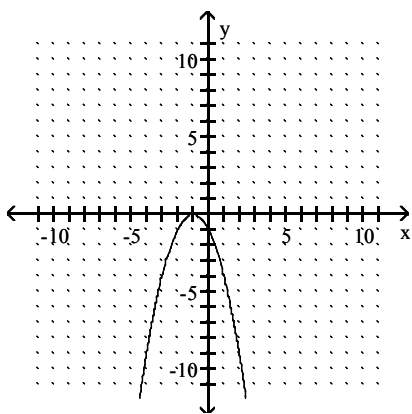

Answer Key

Testname: PRACTICE FOR THE EXAM (3.6)

19)

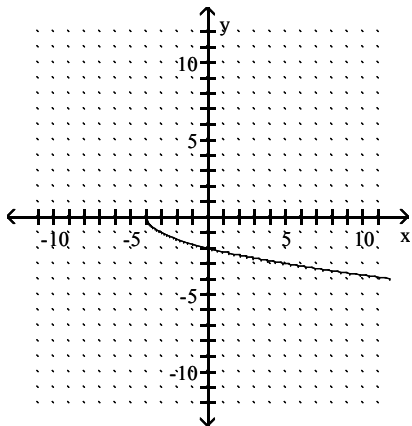

20)

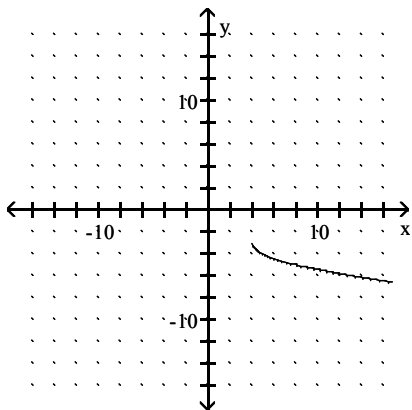

21)

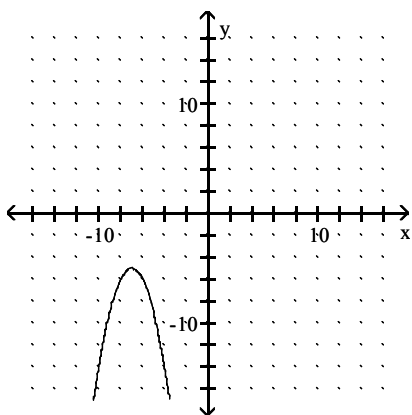

Answer Key

Testname: PRACTICE FOR THE EXAM (3.6)

22)

